

Curved Blade Grilles



Aluminium Construction

Variety of Discharge Patterns

High Quality, Aesthetic Design & Finish

Product Overview Curved Blade Grilles

Supply
51C Series Aluminium

Models:
51C
One, Two, Three or Four-way
Discharge Pattern

51CD
One or Two-way Discharge
Pattern with Rear Directional
Vaness



The **Advanced Air Model Series 51C Curved Blade Grilles** are designed to meet the demand for top quality and competitive prices. The grilles are carefully constructed to be unobtrusive in appearance for architectural excellence. The grilles may be used in ceiling and also side wall applications. They are suitable for Variable Air Volume Systems.

The **Model Series 51CD** incorporate a set of rear vanes that are individually adjustable for complete directional control and flow equalization.

Features:

- Blades are formed to an engineered contoured cross-section. Both ends of each blade are mounted in friction pivots to allow individual blade adjustment without loosening or clattering.
- Adjustable Pattern - the grille blades are easily adjustable to provide a horizontal one-way, two-way, three-way or four-way air path from a ceiling location. A full down-blow position is also available as required.
- Optional opposed blade damper has a screwdriver slot operator for adjustment through the face of the grille.
- Screw holes in the frame are counter-sunk for neat appearance (standard). 38mm long oval-head screws, painted to match grille, are supplied.
- Concealed mountings are available (option).

Material:

Extruded aluminium

Finish:











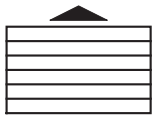
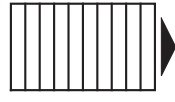

AW Appliance White polyester powder finish RAL 9010 semi-gloss.

Special finishes are available.

Curved Blade Ceiling Grilles

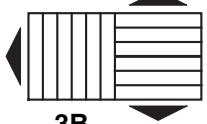
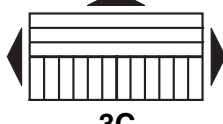
- The **51C Series Grilles** are available in any of the discharge patterns shown below. The blades are individually adjustable for each discharge direction, they can control both volume and angle discharge.

Available Discharge Patterns

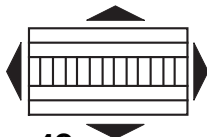
BLOW	RECTANGULAR OR SQUARE
 1-WAY	 1A  1B
 2-WAY	 2A  2B
 2-WAY CORNER	 2C  2D
 3-WAY	 3A  3B  3C
 4-WAY	 4A  4B  4C

Aluminium Curved Blade Grilles

Supply

Models:

51C and 51CD
with One and Two-way
Discharge Pattern

(Suffix 'OA' adds opposed
blade damper)

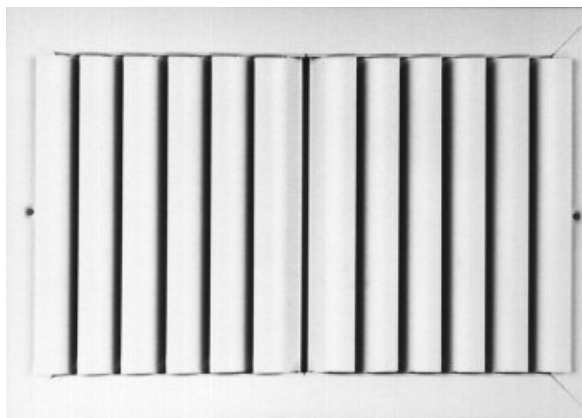

Models 51C and 51CD are supply grilles which incorporate individually adjustable curved blades. The blades can be positioned to provide one-way, two-way and two-way corner-blow discharge air patterns. They are commonly used in ceiling and/or side wall locations and are recommended for use in both heating and cooling applications.

Both one-way and two-way pattern grilles can be adjusted to full or partial down-blow position. The curved streamlined blades are adjusted to a uniform partially closed position to deflect the air path horizontally while retaining an effective area capacity of 35% of the neck area. In the full down-blow position grille effective area is increased to 75%.

Features:

- High quality, extruded aluminium construction.
- 30mm wide face border with a 25mm overlap margin standard, supplied with countersunk screw holes and mounting screws. NF Narrow Frame with 25mm face border optional. Concealed mounting is optional.
- Extruded aluminium frames, mechanically interlocked with reinforced mitred corners.
- Extruded blades - curved streamlined aluminium blades on 25mm centres. Blades formed with tenons to fit snugly into the side margin, friction loaded to firmly hold deflection setting.
- Integral dampers - aluminium. Opposed blade design with a screwdriver slot operator.
- Adjustable pattern - grille blades easily adjustable to provide horizontal one-way or two-way air path from a ceiling location. Adjustable to a full down-blow position as required.
- AW Appliance White polyester powder finish RAL 9010 semi-gloss is standard. Other finishes are also available.
- Standard sizes are available from 150mm x 100mm to 900mm x 900mm. Other sizes are available on request but are subject to manufacturing limitations.

Model 51C One-way Blow (1A)

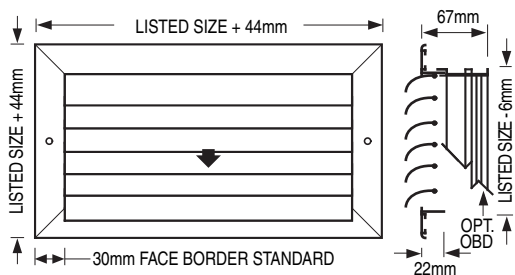

Model 51CD One-way Blow (1A) with Rear Directional Vanes

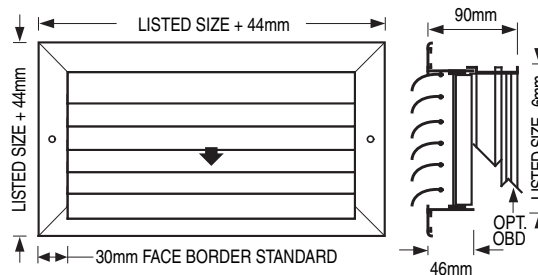

Model 51C Two-way Blow (2A)

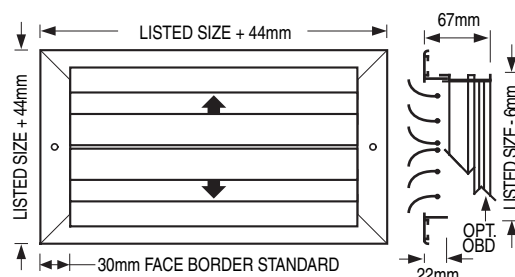

Model 51CD Two-way Blow (2A) with Rear Directional Vanes

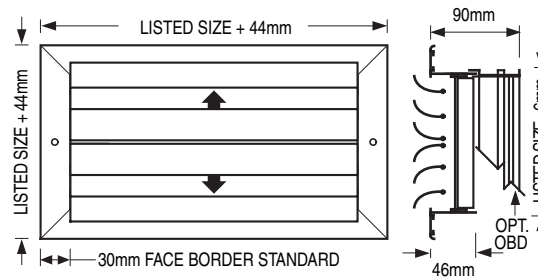

Aluminium Curved Blade Grilles

Supply

Model: 51C with Three and Four-way Discharge Pattern

(Suffix 'OA' adds opposed blade damper)

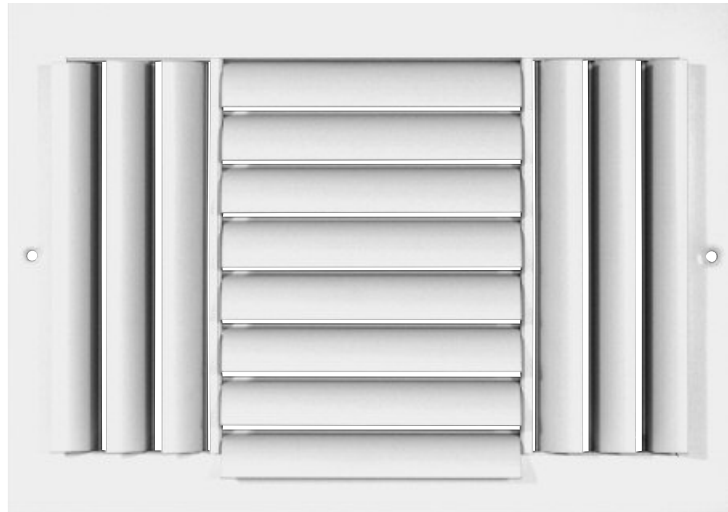

Model 51C Pattern 3A, 3B or 3C Supply Ceiling Grilles have individually adjustable curved blades arranged to provide a three-way ceiling air pattern. **Model 51C Pattern 4A, 4B or 4C Supply Ceiling Grilles** have individually adjustable curved blades arranged to provide a four-way ceiling air pattern. They are recommended for applications in ceiling locations for heating and cooling systems.

Both three-way and four-way pattern grilles can be adjusted to full or partial down-blow position. The curved streamlined blades are adjusted to a uniform partially closed position to deflect the air path horizontally while retaining an effective area capacity of 35% of the neck area. In the full down-blow position grille effective area is increased to 75%.

Features:

- High quality, extruded aluminium construction.
- 30mm wide face border with a 25mm overlap margin standard, supplied with countersunk screw holes and mounting screws.
- NF Narrow Frame with 25mm face border optional. Concealed mounting is optional.
- Extruded aluminium frames, mechanically interlocked with reinforced mitred corners.
- Extruded blades - curved streamlined aluminium blades on 25mm centres. Blades formed with tenons to fit snugly into the side margin, friction loaded to firmly hold deflection setting.
- Integral dampers - aluminium. Opposed blade design with a screwdriver slot operator.
- Adjustable pattern - grille blades easily adjustable to provide horizontal three-way or four-way air path from a ceiling location. Adjustable to a full down-blow position as required.
- AW Appliance White polyester powder finish RAL 9010 semi-gloss is standard. Other finishes are available.
- Available from 150mm x 100mm to 900mm x 900mm.

Model 51C Three-way Blow (3A)

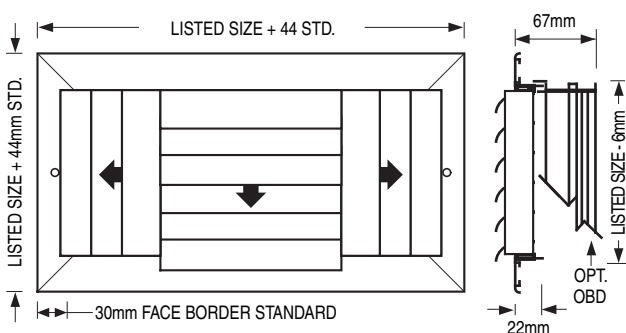

Model 51C Four-way Blow (4C)

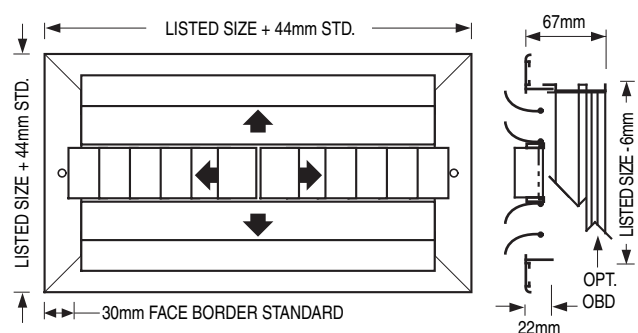

How To Specify or To Order

(Show complete Model Number and Size, unless "Default" is desired)

Aluminium Curved Blade Grilles - Model Series 51C.

51C - OA - 600 x 300 - S - AW - A - 4C - AB - PF

Model

- Aluminium 51C
- Aluminium w/rear vanes 51CD

Damper (OBD)

- Aluminium OA
- No Damper —

Width

mm

Height

mm

Frame/Border Type

Surface Mount:

- Standard 30mm (default) S
- Narrow 25mm NF
- Lay In L

Accessories

- None (default) —
- Foam Gasket GK

Front Blades

- Adjustable (default) AB

Blow Pattern

- 1-way long 1A
- 1-way short 1B
- 2-way long 2A
- 2-way short 2B
- 2-way corner 2C
- 2-way corner 2D
- 3-way short 3A
- 3-way long 3B
- 3-way long 3C
- 4-way long 4A
- 4-way equal 4B
- 4-way short 4C













Fastening

(only for frame/border types S, NF)

- Screw Holes (default) A
- Concealed Mounting Straps C
- None N

Finish

- Appliance White (default) AW
- Aluminium AL
- Mill MI
- Special custom colour SP

AVAILABLE DISCHARGE PATTERNS	
→ 1-WAY	 
↕ 2-WAY	 
↙↘ 2-WAY CORNER	 
↔↕ 3-WAY	  
↕↔↕ 4-WAY	  

Note:

1. 25mm NF narrow frame only available on **51C** Series.
2. Model 51CD is only available with blow patterns 1-way and 2-way.

Performance Data

Curved Blade • Supply

Models: 51C, 51CD

Core Area (m ²)	Nominal Duct Size (mm)	Core Velocity (m/s)	0.5	1.0	1.5	2.0	2.5	3.0	3.5	4.0	
		Pressure Drop (Pa)	1	4	8	15	24	35	46	59	
0.01	150x100	Flowrate (l/s)	5	12	17	24	28	33	40	45	
		NC Level	—	—	—	14	20	23	27	30	
		Throw (m)	4-Way				2.1 - 3.4	2.4 - 4.0	3.1 - 4.9	3.7 - 5.5	4.0 - 6.1
			3-Way				2.1 - 3.7	1.8 - 4.3	3.4 - 4.9	3.7 - 5.8	4.3 - 6.7
			2-Way				2.4 - 4.0	3.1 - 4.9	3.7 - 5.5	4.3 - 6.4	4.9 - 7.3
1-Way					3.1 - 4.9	3.7 - 5.5	4.3 - 6.7	4.9 - 7.9	5.5 - 8.8		
0.01	200x100	Flowrate (l/s)	7	14	24	31	38	45	52	61	
		NC Level	—	—	—	15	20	25	29	31	
		Throw (m)	4-Way			1.8 - 2.7	2.1 - 3.7	2.7 - 4.3	3.4 - 4.9	3.7 - 5.8	4.3 - 6.4
			3-Way			1.8 - 3.1	2.4 - 4.0	2.7 - 4.6	3.7 - 5.5	4.3 - 6.4	4.6 - 7.0
			2-Way			2.1 - 3.4	2.7 - 4.3	3.4 - 4.9	4.0 - 6.1	4.6 - 7.0	4.9 - 7.9
1-Way				3.1 - 4.9	3.4 - 4.9	4.0 - 6.1	4.9 - 7.3	5.2 - 8.5	5.8 - 9.5		
0.02	250x100 150x150	Flowrate (l/s)	9	19	28	38	47	57	66	76	
		NC Level	—	—	—	15	21	26	29	32	
		Throw (m)	4-Way			1.8 - 2.7	2.4 - 4.0	2.7 - 4.6	3.4 - 5.2	4.0 - 6.1	4.6 - 7.0
			3-Way			1.8 - 3.1	2.7 - 4.3	3.1 - 4.9	3.7 - 5.8	4.3 - 6.7	4.9 - 7.6
			2-Way			2.1 - 3.4	2.7 - 4.6	3.4 - 5.2	4.3 - 6.4	4.9 - 7.3	5.2 - 8.5
1-Way				2.7 - 4.3	3.4 - 5.2	4.3 - 6.4	4.9 - 7.6	5.5 - 8.8	6.1 - 10.1		
0.02	300x100 200x150	Flowrate (l/s)	12	24	38	50	61	73	85	99	
		NC Level	—	—	—	16	22	27	30	33	
		Throw (m)	4-Way		1.2 - 2.1	1.8 - 3.1	2.7 - 4.3	3.1 - 4.9	3.7 - 5.8	4.3 - 6.7	4.9 - 7.6
			3-Way		1.2 - 2.1	2.1 - 3.4	2.7 - 4.6	3.4 - 5.2	4.0 - 6.1	4.6 - 7.0	4.9 - 7.9
			2-Way		1.5 - 2.4	2.1 - 3.7	3.1 - 4.9	3.7 - 5.8	4.6 - 7.0	4.9 - 7.9	5.5 - 9.2
1-Way			1.8 - 3.1	2.7 - 4.6	3.7 - 5.5	4.6 - 7.0	5.2 - 8.2	5.8 - 9.5	6.7 - 11.0		
0.03	350x100	Flowrate (l/s)	14	28	42	57	71	85	99	113	
		NC Level	—	—	—	17	22	27	31	34	
		Throw (m)	4-Way		1.2 - 2.1	1.8 - 3.1	2.7 - 4.3	3.4 - 4.9	4.0 - 6.1	4.6 - 7.0	4.9 - 7.9
			3-Way		1.5 - 2.4	2.1 - 3.4	2.7 - 4.6	3.7 - 5.5	4.3 - 6.4	4.9 - 7.3	5.2 - 8.5
			2-Way		1.8 - 2.7	2.4 - 4.0	3.4 - 4.9	4.0 - 6.1	4.6 - 7.0	5.2 - 8.2	5.8 - 9.5
1-Way			1.8 - 3.1	2.7 - 4.6	3.7 - 5.8	4.9 - 7.3	5.3 - 8.5	6.1 - 10.1	7.0 - 11.3		
0.03	400x100 250x150 200x200	Flowrate (l/s)	17	33	50	66	83	99	116	132	
		NC Level	—	—	10	18	23	28	31	35	
		Throw (m)	4-Way		1.2 - 2.1	2.1 - 3.4	2.7 - 4.6	3.4 - 5.2	4.0 - 6.1	4.9 - 7.3	5.2 - 8.2
			3-Way		1.5 - 2.4	2.1 - 3.7	2.7 - 4.6	3.7 - 5.5	4.3 - 6.7	4.9 - 7.6	5.5 - 8.8
			2-Way		1.8 - 2.7	2.4 - 4.0	3.4 - 4.9	4.0 - 6.1	4.9 - 7.3	5.2 - 8.5	6.1 - 9.8
1-Way			1.8 - 3.1	3.1 - 4.9	4.0 - 6.1	4.9 - 7.3	5.5 - 8.8	6.4 - 10.4	7.3 - 11.9		
0.04	450x100 300x150	Flowrate (l/s)	19	38	57	76	94	113	132	151	
		NC Level	—	—	12	19	24	29	32	35	
		Throw (m)	4-Way		1.5 - 2.4	2.1 - 3.4	2.7 - 4.6	3.7 - 5.5	4.3 - 6.4	4.9 - 7.6	5.2 - 8.5
			3-Way		1.5 - 2.4	2.1 - 3.7	3.1 - 4.9	3.7 - 5.8	4.6 - 7.0	4.9 - 7.9	5.5 - 9.2
			2-Way		1.8 - 2.7	2.7 - 4.3	3.4 - 5.2	4.3 - 6.4	4.9 - 7.6	5.5 - 8.8	6.1 - 10.1
1-Way			1.8 - 3.1	3.1 - 4.9	4.3 - 6.4	4.9 - 7.6	5.5 - 9.2	6.4 - 10.7	7.6 - 12.2		
0.04	500x100 350x150 250x200	Flowrate (l/s)	21	42	64	85	106	127	149	170	
		NC Level	—	—	12	19	25	29	32	36	
		Throw (m)	4-Way		1.5 - 2.4	2.1 - 3.7	2.7 - 4.6	3.7 - 5.5	4.3 - 6.7	4.9 - 7.6	5.5 - 8.8
			3-Way		1.5 - 2.4	2.4 - 4.0	3.4 - 4.9	4.0 - 6.1	4.6 - 7.0	5.2 - 8.2	5.8 - 9.5
			2-Way		1.8 - 2.7	2.7 - 4.3	3.7 - 5.5	4.3 - 6.7	4.9 - 7.9	5.5 - 9.2	6.4 - 10.4
1-Way			2.1 - 3.4	3.4 - 4.9	4.3 - 6.4	4.9 - 7.9	5.8 - 9.5	6.7 - 11.0	7.6 - 12.5		
0.05	600x100 400x150 300x200	Flowrate (l/s)	26	52	78	104	130	156	182	208	
		NC Level	—	—	13	20	25	29	33	37	
		Throw (m)	4-Way	0.9 - 1.2	1.5 - 2.4	2.1 - 3.7	3.1 - 4.9	3.7 - 5.8	4.6 - 7.0	5.2 - 8.2	5.5 - 9.2
			3-Way	0.9 - 1.5	1.8 - 2.7	2.4 - 4.0	3.4 - 5.2	4.3 - 6.4	4.9 - 7.6	5.5 - 8.8	6.1 - 9.8
			2-Way	0.9 - 1.5	1.8 - 3.1	2.7 - 4.6	3.7 - 5.8	4.6 - 7.0	5.2 - 8.5	7.9 - 9.8	6.7 - 11.0
1-Way	1.2 - 1.8		2.1 - 3.7	3.4 - 5.2	4.3 - 6.7	5.2 - 8.5	6.1 - 10.1	7.0 - 11.6	7.9 - 13.1		

Performance Data

Curved Blade • Supply

Models: 51C, 51CD

Core Area (m ²)	Nominal Duct Size (mm)	Core Velocity (m/s)	0.5	1.0	1.5	2.0	2.5	3.0	3.5	4.0	
		Pressure Drop (Pa)	1	4	8	15	24	35	46	59	
0.06	450x150 250x250	Flowrate (l/s)	28	59	87	118	146	175	205	234	
		NC Level	—	—	12	20	26	30	34	37	
		Throw (m)	4-Way	0.9 - 1.2	1.8 - 2.7	2.4 - 4.0	3.4 - 4.9	4.0 - 6.1	4.9 - 7.3	5.2 - 8.2	5.8 - 6.4
			3-Way	0.9 - 1.5	1.8 - 2.7	2.7 - 4.3	3.4 - 5.2	4.3 - 6.4	4.9 - 7.9	5.5 - 9.2	6.1 - 10.1
			2-Way	0.9 - 1.5	1.8 - 3.1	2.7 - 4.6	3.7 - 5.8	4.9 - 7.3	5.2 - 8.5	6.1 - 10.1	7.0 - 11.3
1-Way	1.2 - 1.8		2.1 - 3.7	3.4 - 5.3	4.6 - 8.2	5.5 - 8.8	6.4 - 7.3	7.6 - 12.2	8.5 - 13.7		
0.07	750x100 500x150 350x200 300x250	Flowrate (l/s)	33	66	99	132	165	198	231	264	
		NC Level	—	—	14	20	26	30	34	38	
		Throw (m)	4-Way	0.9 - 1.5	1.8 - 2.7	2.4 - 4.0	3.4 - 4.9	4.0 - 6.1	4.9 - 7.3	5.8 - 8.5	6.1 - 9.8
			3-Way	0.9 - 1.5	1.8 - 2.7	2.7 - 4.3	3.7 - 5.5	4.3 - 6.7	4.9 - 7.9	5.8 - 9.5	6.4 - 10.7
			2-Way	1.2 - 1.8	2.1 - 3.4	3.1 - 4.9	4.0 - 6.1	4.9 - 7.3	5.5 - 8.8	6.4 - 10.4	7.3 - 11.9
1-Way	1.2 - 2.1		2.4 - 4.0	3.7 - 5.5	4.9 - 7.3	5.5 - 8.8	6.4 - 10.7	7.6 - 12.5	8.5 - 14.0		
0.08	900x100 600x150 400x200 350x250	Flowrate (l/s)	38	76	116	153	191	229	267	307	
		NC Level	—	—	15	21	27	31	35	38	
		Throw (m)	4-Way	0.9 - 1.5	1.8 - 2.7	2.7 - 4.3	3.4 - 5.2	4.3 - 6.4	4.9 - 7.6	5.5 - 8.8	6.1 - 10.1
			3-Way	0.9 - 1.5	1.8 - 3.1	2.7 - 4.6	3.7 - 5.8	4.9 - 7.6	5.2 - 8.2	6.1 - 9.8	6.7 - 11.0
			2-Way	1.2 - 1.8	2.1 - 3.4	3.1 - 4.9	4.3 - 6.4	4.9 - 7.6	5.5 - 9.2	6.4 - 10.7	7.6 - 12.2
1-Way	1.2 - 2.1		2.4 - 4.0	3.7 - 5.5	4.9 - 7.6	5.8 - 9.5	7.0 - 11.3	7.9 - 13.1	9.2 - 14.6		
0.08	450x200 300x300	Flowrate (l/s)	40	83	123	165	205	245	288	328	
		NC Level	—	—	15	21	27	31	35	38	
		Throw (m)	4-Way	0.9 - 1.5	1.8 - 2.7	2.7 - 4.3	3.7 - 5.5	4.3 - 6.7	4.9 - 7.9	5.5 - 9.2	6.4 - 10.4
			3-Way	1.2 - 1.8	1.8 - 3.1	2.7 - 4.6	3.7 - 5.8	4.9 - 7.3	5.2 - 8.5	6.1 - 9.8	7.0 - 11.3
			2-Way	1.2 - 1.8	2.1 - 3.4	3.4 - 4.9	4.3 - 6.4	4.9 - 7.9	5.8 - 9.5	6.7 - 11.0	7.6 - 12.5
1-Way	1.2 - 2.1		2.7 - 4.3	3.7 - 5.8	4.9 - 7.6	5.8 - 9.2	7.0 - 11.6	8.2 - 13.4	9.2 - 14.9		
0.09	750x150 500x200 400x250 350x300	Flowrate (l/s)	47	97	144	194	241	288	337	385	
		NC Level	—	—	15	22	28	32	36	39	
		Throw (m)	4-Way	0.9 - 1.5	1.8 - 3.1	2.7 - 4.6	3.7 - 5.5	4.6 - 7.0	5.2 - 8.2	5.8 - 9.5	6.4 - 10.7
			3-Way	1.2 - 1.8	1.8 - 3.1	3.1 - 4.9	4.0 - 6.1	4.9 - 7.3	5.5 - 8.8	6.4 - 10.4	7.0 - 11.6
			2-Way	1.2 - 1.8	2.1 - 3.7	3.4 - 4.9	4.3 - 6.7	5.2 - 8.2	6.1 - 9.8	7.0 - 11.6	7.9 - 12.8
1-Way	1.5 - 2.4		2.7 - 4.3	4.0 - 6.1	4.9 - 7.9	6.1 - 10.1	7.3 - 11.0	8.5 - 13.7	9.5 - 15.3		
0.11	600x200 450x250 400x350	Flowrate (l/s)	54	109	163	217	271	326	380	434	
		NC Level	—	—	16	23	29	32	36	40	
		Throw (m)	4-Way	0.9 - 1.5	1.8 - 3.1	2.7 - 4.6	3.7 - 5.8	4.9 - 7.3	5.2 - 8.5	6.1 - 9.8	7.0 - 11.3
			3-Way	1.2 - 1.8	2.1 - 3.4	3.1 - 4.9	4.0 - 6.1	4.9 - 7.6	5.5 - 9.2	6.4 - 10.7	7.6 - 12.2
			2-Way	1.2 - 1.8	2.1 - 3.7	3.4 - 5.2	4.3 - 6.7	5.2 - 8.5	6.1 - 10.1	7.3 - 11.9	8.2 - 13.4
1-Way	1.5 - 2.4		2.7 - 4.6	4.3 - 6.4	5.2 - 8.2	6.4 - 10.4	7.6 - 12.2	8.5 - 14.0	10.1 - 16.2		
0.12	900x100 500x250 350x350	Flowrate (l/s)	59	118	177	236	295	354	413	472	
		NC Level	—	—	16	23	29	33	37	40	
		Throw (m)	4-Way	1.2 - 1.8	1.8 - 3.1	2.7 - 4.6	3.7 - 5.8	4.9 - 7.3	5.2 - 8.5	6.1 - 10.1	7.0 - 11.3
			3-Way	1.2 - 1.8	2.1 - 3.4	3.1 - 4.9	4.3 - 6.4	4.9 - 8.5	5.8 - 9.5	6.7 - 11.0	7.6 - 12.2
			2-Way	1.2 - 2.1	2.1 - 3.7	3.4 - 5.2	4.6 - 7.0	5.5 - 8.8	6.4 - 10.4	7.6 - 12.2	8.5 - 13.7
1-Way	1.5 - 2.4		2.7 - 4.6	4.3 - 6.1	5.2 - 8.5	6.4 - 10.4	7.6 - 12.2	8.8 - 14.3	10.1 - 16.2		
0.13	400x350 450x300	Flowrate (l/s)	64	127	191	255	319	382	446	510	
		NC Level	—	—	16	23	29	33	37	40	
		Throw (m)	4-Way	1.2 - 1.8	1.8 - 3.1	3.1 - 4.9	4.0 - 6.1	4.9 - 7.3	5.5 - 8.8	6.4 - 10.4	7.0 - 11.6
			3-Way	1.2 - 1.8	2.1 - 3.4	3.4 - 4.9	4.3 - 6.4	4.9 - 8.5	5.8 - 9.5	6.7 - 11.0	7.6 - 12.5
			2-Way	1.2 - 2.1	2.4 - 4.0	3.7 - 5.5	4.9 - 7.3	5.5 - 8.8	6.4 - 10.7	7.6 - 12.5	8.5 - 14.0
1-Way	1.5 - 2.4		2.7 - 4.6	4.3 - 6.7	5.2 - 8.5	6.4 - 10.7	7.9 - 12.8	9.2 - 14.9	10.4 - 16.5		
0.14	750x200 600x250 500x300 450x350 400x400	Flowrate (l/s)	73	144	217	288	361	434	505	576	
		NC Level	—	—	17	24	29	34	38	41	
		Throw (m)	4-Way	1.2 - 1.8	2.1 - 3.4	3.1 - 4.9	4.0 - 6.1	4.9 - 7.6	5.5 - 9.2	6.4 - 10.7	7.3 - 11.9
			3-Way	1.2 - 1.8	2.1 - 3.7	3.4 - 4.9	4.3 - 6.4	5.2 - 8.2	6.1 - 9.8	7.0 - 11.6	7.9 - 13.1
			2-Way	1.2 - 2.1	2.4 - 4.0	3.7 - 5.5	4.9 - 7.3	5.8 - 9.5	6.7 - 11.0	7.9 - 12.8	8.8 - 14.0
1-Way	1.5 - 2.4		3.1 - 4.9	4.3 - 6.7	5.5 - 8.8	6.7 - 11.0	7.9 - 13.1	9.5 - 14.9	10.7 - 14.9		