

# Advanced Air (UK) Limited

## ACCESS DOORS

### 0800 SERIES



### F e a t u r e s

Choice of five ergonomic sizes.

Thermal, acoustic and fire retardant insulation.

Double skin, sandwich construction lift off doors.

Simple progressive camlock fastening.

Positive seal gasket.

Pre-punched flange holes for easy installation.

Safety retaining chain as standard.

Oval shape for easy cut-out, template provided with each carton.

Suitable for plain and insulated ducting.

### A p p r o v a l s

Conformance to DW142 Class AB&C.  
(to Class D with additional seal)

Shock tested to DEF Std 07-55

Quality Assurance system assessed to BS EN ISO 9002



# ACCESS DOORS

## ERGONOMIC SIZING

The standard duct access door sizes have been selected after careful study of the needs of site engineering and maintenance personnel. Each door allows a different degree of access, enabling the most appropriate unit to be specified, depending on the type of equipment installed in the ducting, and the likely maintenance needs.



**0800**  
hand / sight



**0810**  
one hand and sight



**0820**  
two hands and sight



**0830**  
head and shoulders

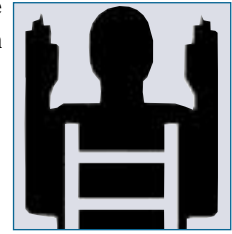

**0840**  
body entry plus ladder

**NOTE** These additional camlocks on model 0820 only.

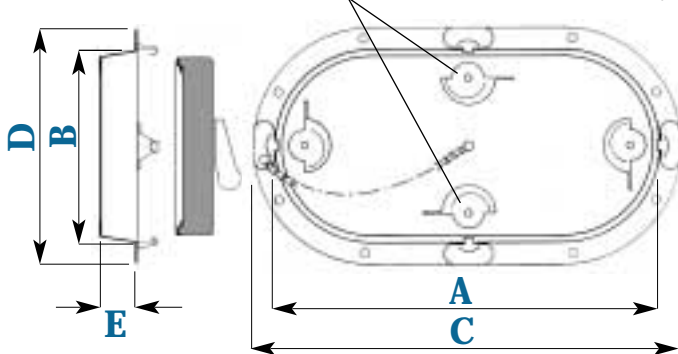

MODEL	0800	0810	0820
Nom Size	200 x 125	300 x 150	460 x 250
A	203	298	462
B	127	157	258
C	241	349	502
D	165	197	298
E	30	30	30

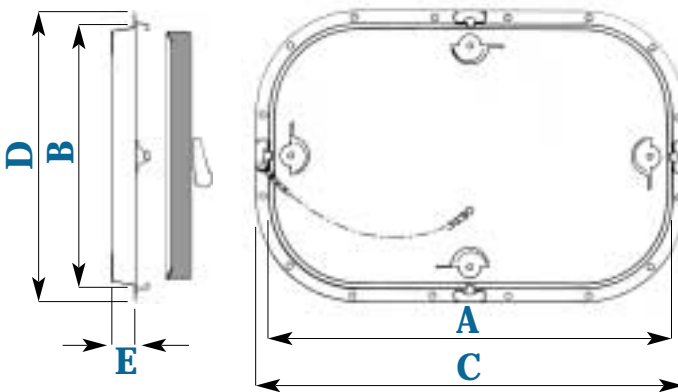

MODEL	0830	0840
Nom Size	530 x 360	635 x 430
A	538	640
B	355	433
C	578	679
D	400	476
E	30	30

*To achieve leakage rates to Class D of DW142, an additional seal is required on models 0830 and 0840. Optional upon request*

## MOUNTING METHODS

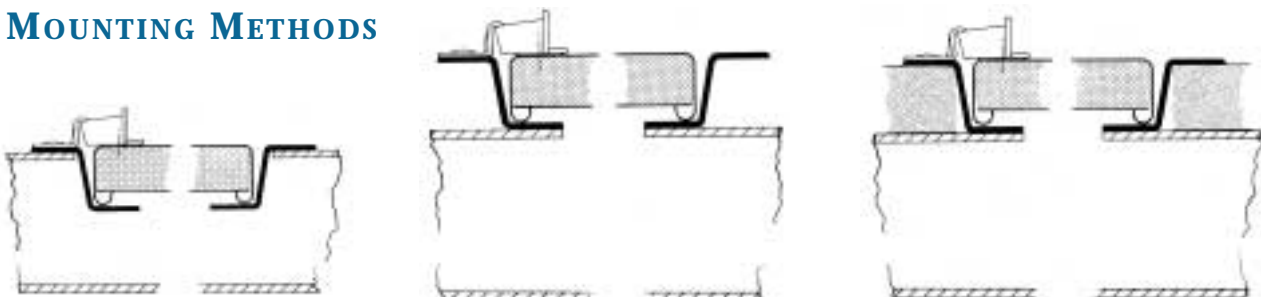

**SPECIAL NOTE** To achieve the optimum seal, ducting should be suitably reinforced so that panting/bowing does not occur, thus ensuring frames retain their designed shape and profile.

## SPECIAL FRAME OPTIONS

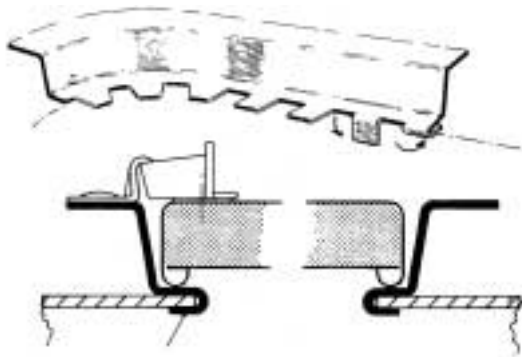

Fish Tab fixing to models 0800, 0810 and 0820 as illustrated.

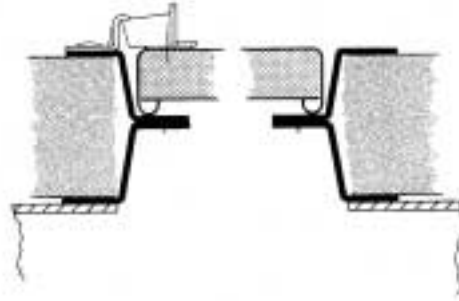

When 50 mm insulation is required, two frames supplied loose can be site fixed back to back to allow for the 50mm insulation. Note:- The double skinned door contains 20 mm thick insulation.

## DOOR OPTIONS

A plexiglass sight window for inspection and maintenance is available on all models except the 0800.

The window on the 0810 is flat-oval (as shown below) and the windows on the 0820, 0830 and 0840 models are circular (as shown on the front cover).

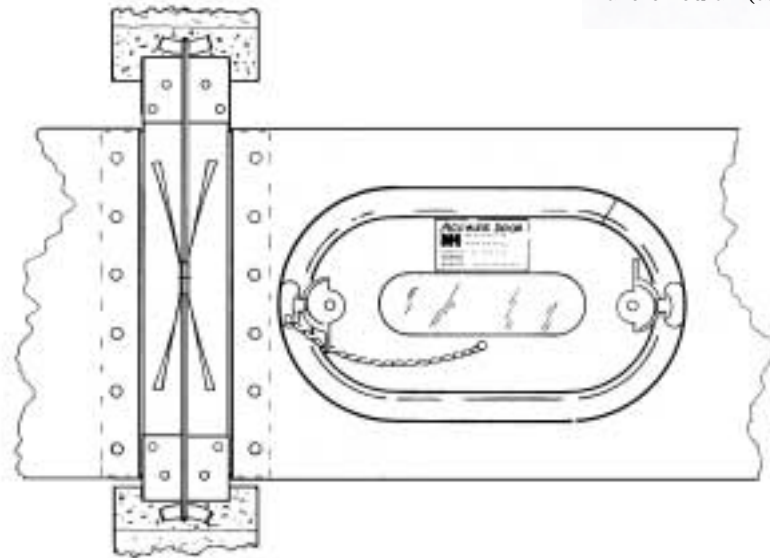

## WEIGHT AND CONSIGNMENT DATA

MODEL	NOMINAL SIZE MM	No. per Carton	Weight per Carton Kg	Volume per Carton M <sup>3</sup>
0800	200 x 125	20	14	.041
0810	300 x 150	10	11	.036
0820	460 x 250	10	22	.074
0830	530 x 360	5	16	.061
0840	635 x 430	4	18	.068

A cutting template is included with each carton.

## MATERIAL AND SPECIFICATIONS

FRAME	SEAMLESS ONE PIECE PRESSED 0.7 MM GALVANISED MILD STEEL.
DOOR	TWO SECTION CONSTRUCTION COMPRISING AN OUTER PANEL AND AN INNER PANEL, BOTH MANUFACTURED FROM 0.7 MM GALVANISED MILD STEEL.
INSULATION	20 MM INSULATION, GIVING EXCELLENT THERMAL, ACCOUSTIC AND FIRE RETARDANT CHARACTERISTICS.
SEAL	ONE PIECE, LONG MEMORY, COMPRESSION SEAL. (FOR USE UP TO 80 <sup>0</sup> C)
FASTENERS	PROGRESSIVE ACTION ZINC PLATED CAM-LOCK FASTENERS.
RETAINING CHAIN	A SAFETY RETAINING CHAIN IS FITTED AS STANDARD TO FRAME/DOOR.

## TYPICAL ORDER DETAIL

MODEL REF	SIZE (W x H)MM	QUANTITY
<b>0820-17</b>	<b>460 x 250</b>	<b>20 (2 BOXES )</b>

### FULL 6 DIGIT ORDERING LEGEND

PRODUCT GROUP	MODEL	MOUNTING TYPE	OPTIONS
08	00	17. STANDARD UNIT	PLEXIGLASS WINDOWS (FOR MODELS: 0810, 0820, 0830, 0840.)
	10	20. FISH TAB FRAME (NO SAFETY CHAIN OR INSTALLATION HOLES)	
	20	60. STANDARD FRAME ONLY (IE. NO DOOR).	ADDITIONAL SEAL FOR CLASS D ( ONLY REQUIRED FOR MODELS 0830 & 0840)
	30		
	40		

## ASSOCIATED PRODUCTS

Other fully tested and approved product groups include:

- ◆ SERIES 0100/ 0200 - CURTAIN FIRE DAMPERS
- ◆ SERIES 1000 - UNIVERSAL VOLUME CONTROL DAMPERS
- ◆ SERIES 1200 - FIRE/SMOKE / CONTROL DAMPERS
- ◆ SERIES 1400 - SLIMLINE BALANCE AND CONTROL DAMPERS
- ◆ SERIES 2300 - LEAKAGE RATED FIRE / SMOKE DAMPERS
- ◆ SERIES 2400 - INSULATED FIRE / SMOKE DAMPERS
- ◆ SERIES 4000 - FIRE RATED DIFFUSER ASSEMBLIES
- ◆ SYSTEM 21 - SMOKE AND FIRE DAMPER CONTROL

The information contained in this publication is correct at the time of printing. Continuous product development means that from time to time product specifications and other information will change. The company therefore reserves the right to modify or withdraw any of the products described without prior notice



**Advanced Air**  
(UK) Limited

3 Cavendish Road Bury St Edmunds Suffolk IP33 3TE England  
Tel 01284 701356 Fax 01284 701357  
Email: sales@advancedair.co.uk

